



254-1200-2

Quick Clamp Reversible 48"



PRODUCT DETAILS

- Professional F-clamp
- Ratcheting system for easy adjustment and clamping
- Length 300 to 600 mm
- High clamping capacity, up to 510 kg
- Capacity 200 to 600 mm
- Steel guide, body and jaws
- Aluminium handle with plastic trigger
- Non-slip braking mechanism
- Fix top pad and swivel bottom pad.
- Retail packaging with tag for relevant information

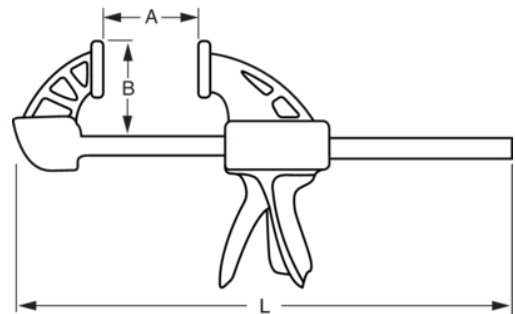

PRODUCT ATTRIBUTES

Product	L	A	B	
254-1200-2	1385 mm	1200 mm	60 mm	1165 g